



BRIGGS & STRATTON

®

Operating & Maintenance Instructions

The Power That Works For You®





**Model 12K300 Intek™ Series for Pump applications
covered in this manual**

Safety References



The safety alert symbol () is used to identify safety information about hazards that can result in personal injury. A signal word (DANGER, WARNING, or CAUTION) is used with the alert symbol to indicate the likelihood and the potential severity of injury. In addition, a hazard symbol may be used to represent the type of hazard.

 **DANGER** indicates a hazard which, if not avoided, **will result in death or serious injury.**

 **WARNING** indicates a hazard which, if not avoided, **could result in death or serious injury.**

 **CAUTION** indicates a hazard which, if not avoided, **might result in minor or moderate injury.**

CAUTION, when used **without** the alert symbol, indicates a situation that **could result in damage to the engine.**

  This manual contains safety information to make you aware of the hazards and risks associated with engines, and how to avoid them. Because Briggs & Stratton does not necessarily know what equipment this engine will power, it is important that you read and understand these instructions and the instructions for the equipment this engine powers.















WARNING

Briggs & Stratton does not approve or authorize the use of these engines on 3-wheel All Terrain Vehicles (ATVs), motor bikes, fun/recreational go-karts, aircraft products or vehicles intended for use in competitive events. Use of these engines in such applications could result in property damage, serious injury (including paralysis), or even death.

Table of Contents

Safety Reference	2
Engine Features	3
Starting Engine	4
Adjusting Choke after Engine has Started	6
Stopping Engine	6
Oil	7
Fuel	8
Engine Maintenance	10
Engine Storage	12
Troubleshooting	13
Engine Specifications	14
Service and Parts Contact Info.	15
Warranty Information	16

SYMBOLS ASSOCIATED WITH THIS ENGINE:

	Fire		Read Manual
	Explosion		Oil
	Kickback		Petrol
	Hot Surface		Kerosene
	Toxic Fumes		Fuel Shutoff
	Moving Parts		On Off
	Shock		Run
			Choke

WARNING

The engine exhaust from this product contains chemicals known to the State of California to cause cancer, birth defects, or other reproductive harm.

CAUTION

This engine is shipped from Briggs & Stratton without oil. If you start the engine without oil, the engine will be damaged beyond repair and will not be covered under warranty.

Engine Emissions



This engine is not certified to be in compliance with the engine emission standards of the United States Environmental Protection Agency (U.S. EPA) the California Air Resources Board (CARB), nor the European Union (EU). This engine cannot be sold in the United States or the European Union. This engine is intended for India use only.

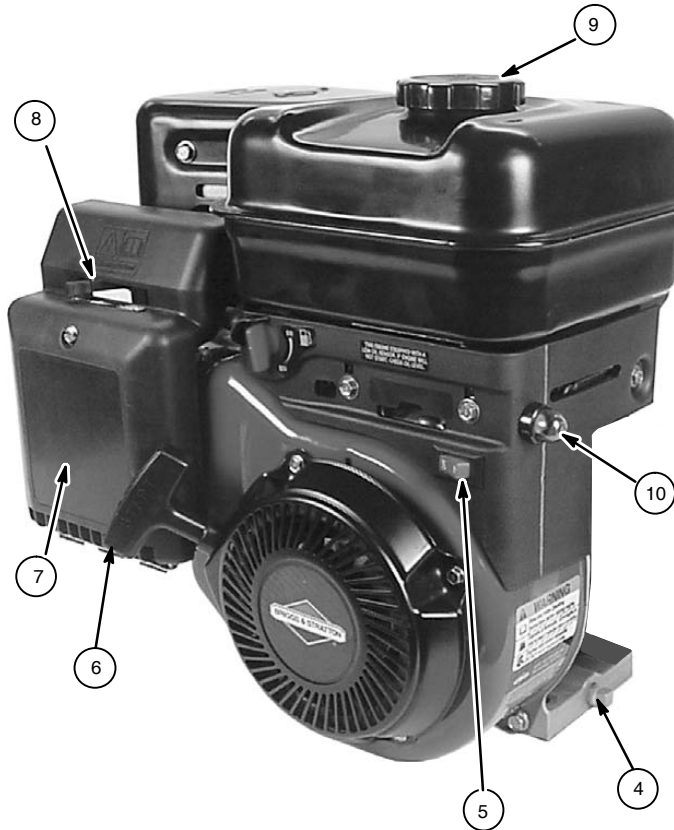
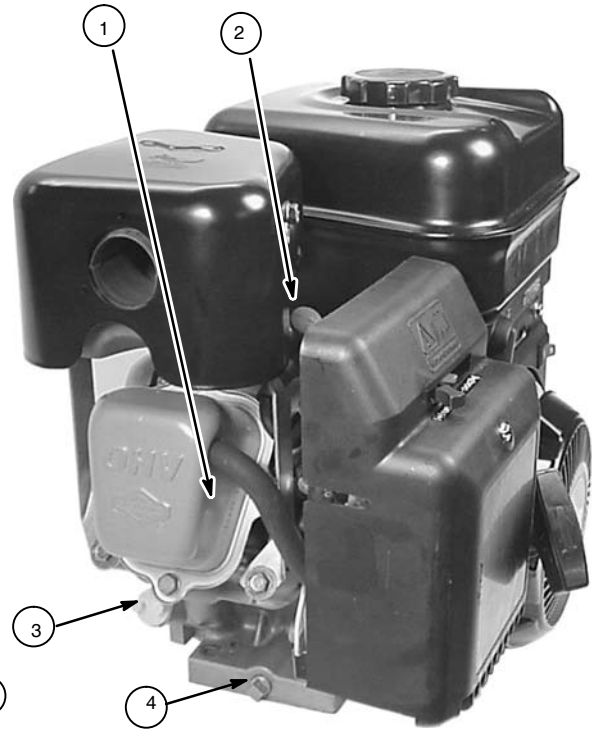

Engine Features

1. Engine Identification **Model Type Code**
2. Spark Plug
3. Oil Fill
4. Oil Drain
5. Stop Switch
6. Starter Handle
7. Air Cleaner
8. Choke Control
9. Kerosene Tank
10. Primer Bulb



Operator Safety

 	<p>! WARNING</p> <p>Kerosene and its vapors are extremely flammable and explosive. Fire or explosion can cause severe burns or death.</p>
<p>WHEN ADDING FUEL</p> <ul style="list-style-type: none">• Turn engine OFF and let engine cool at least 2 minutes before removing fuel cap.• Fill fuel tank outdoors or in well-ventilated area.• Do not overfill fuel tank.• Keep kerosene away from sparks, open flames, pilot lights, heat, and other ignition sources.• Check fuel lines, tank, cap, and fittings frequently for cracks or leaks. Replace if necessary. <p>WHEN STARTING ENGINE</p> <ul style="list-style-type: none">• Make sure spark plug, muffler, fuel cap and air cleaner are in place.• DO NOT start engine with air filter or cover not properly installed. Serious injury or death could result from backfire.• Do not crank engine with spark plug removed.• If fuel spills, wait until it evaporates before starting engine.• If engine floods, set choke to OPEN/RUN position, place throttle in FAST and crank until engine starts. <p>WHEN OPERATING EQUIPMENT</p> <ul style="list-style-type: none">• Do not choke carburetor to stop engine. <p>WHEN TRANSPORTING EQUIPMENT</p> <ul style="list-style-type: none">• Transport with fuel tank EMPTY. <p>WHEN STORING KEROSENE OR EQUIPMENT WITH FUEL IN TANK</p> <ul style="list-style-type: none">• Store away from furnaces, stoves, water heaters or other appliances that have pilot light or other ignition source because they can ignite fuel vapors.	

 	<p>! WARNING</p> <p>Starting engine creates sparking. Sparking can ignite nearby flammable gases. Explosion and fire could result.</p>
<ul style="list-style-type: none">• If there is natural or LP fuel leakage in area, do not start engine.• Do not use pressurized starting fluids because vapors are flammable.	

	<p>! WARNING</p> <p>Engines give off carbon monoxide, an odorless, colorless, poison gas. Breathing carbon monoxide can cause nausea, fainting or death.</p>
<ul style="list-style-type: none">• Start and run engine outdoors.• Do not start or run engine in enclosed area, even if doors or windows are open.	

	<p>! WARNING</p> <p>Rapid retraction of starter cord (kickback) will pull hand and arm toward engine faster than you can let go. Broken bones, fractures, bruises or sprains could result.</p>
<ul style="list-style-type: none">• When starting engine, pull cord slowly until resistance is felt, then pull rapidly.• Direct coupled equipment components such as, but not limited to, blades, impellers, pulleys, sprockets, etc., must be securely attached.	

	<p>! WARNING</p> <p>Rotating parts can contact or entangle hands, feet, hair, clothing, or accessories. Traumatic amputation or severe laceration can result.</p>
<ul style="list-style-type: none">• Operate equipment with guards in place.• Keep hands and feet away from rotating parts.• Tie up long hair and remove jewelry.• Do not wear loose-fitting clothing, dangling drawstrings or items that could become caught.	



WARNING



Running engines produce heat. Engine parts, especially muffler, become extremely hot.

Severe thermal burns can occur on contact.



Combustible debris, such as leaves, grass, brush, etc. can catch fire.

- Allow muffler, engine cylinder and fins to cool before touching.
- Remove accumulated combustibles from muffler area and cylinder area.
- Install and maintain in working order a spark arrester before using equipment on forest-covered, grass-covered, brush-covered unimproved land. The state of California requires this (Section 4442 of the California Public Resources Code). Other states may have similar laws. Federal laws apply on federal land.



WARNING



Unintentional sparking can result in fire or electric shock.



Unintentional start-up can result in entanglement, traumatic amputation, or laceration.



BEFORE PERFORMING ADJUSTMENTS OR REPAIRS

- Disconnect spark plug wire and keep it away from spark plug.
- Do not strike the flywheel with a hammer or hard object because the flywheel may later shatter during operation.
- Do not tamper with governor spring, links or other parts to increase engine speed.
- Use only correct tools.

WHEN TESTING FOR SPARK

- Use approved spark plug tester.
- Do not check for spark with spark plug removed.

Oil Recommendation

Use a high quality detergent oil classified "For Service SF, SG, SH, SJ" or higher.

Do not use special additives.

Determine best grade for use by temperature during operation, see chart.

SAE 30 40°F and higher (5°C and higher)

is good for all purpose use above 40°F, use below 40°F will cause hard starting.

10W-30 0 to 100°F (-18 to 38°C)

is better for varying temperature conditions. This grade of oil improves cold weather starting, but may increase oil consumption at 80°F (27°C) or higher.

★ Check oil level frequently at higher temperatures.

Synthetic 5W-30 -20 to 120°F (-30 to 40°C)

provides the best protection at all temperatures as well as improved starting with less oil consumption.

5W-30 40°F and below (5°C and below)

is recommended for winter use, and works best in cold conditions.

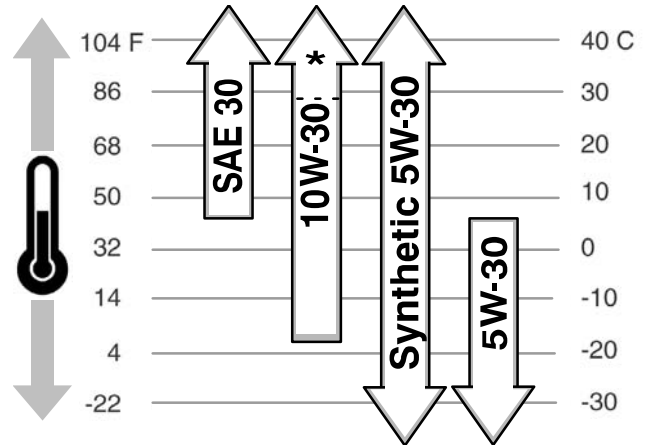

Oil Capacity

The engine holds approximately 5/8 qt. (20 oz; 0.6 liter).

Adding Oil

- Check oil level before starting the engine.
- Keep oil level at FULL.
- Check level daily, or after every eight (8) hours.
 1. Place engine level and clean around oil fill plug. (A)
 2. Remove oil fill plug. Fill oil to point of overflowing. (B)
 3. Replace plug before starting engine.

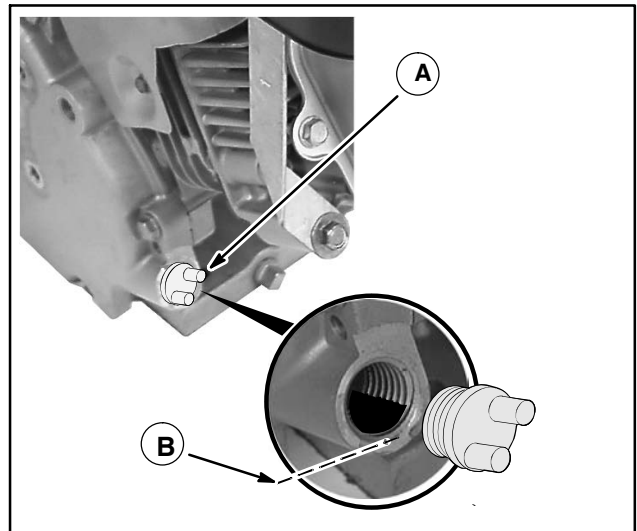

Fuel Recommendation

Kerosene

- Use clean, fresh kerosene. Fresh kerosene prevents gum from forming in the fuel system or on essential carburetor parts. Purchase kerosene in quantity that can be used within 30 days.
- To keep kerosene fresh and protect the engine use a Kerosene Additive.
- Do not mix oil with kerosene.

Adding Fuel

1. Replace cap before starting.
2. Clean area around black kerosene cap and remove. Fill tank to approximately 1-1/2 inches below top of neck to allow for fuel expansion (A). Be careful not to overfill.
3. Replace cap before starting.



WARNING

Kerosene and its vapors are extremely flammable and explosive.

Fire or explosion can cause severe burns or death.

WHEN ADDING FUEL

- Turn engine OFF and let engine cool at least 2 minutes before removing fuel cap.
- Fill fuel tank outdoors or in well-ventilated area.
- Do not overfill fuel tank.
- Keep kerosene away from sparks, open flames, pilot lights, heat, and other ignition sources.
- Check fuel lines, tank, cap, and fittings frequently for cracks or leaks. Replace if necessary.

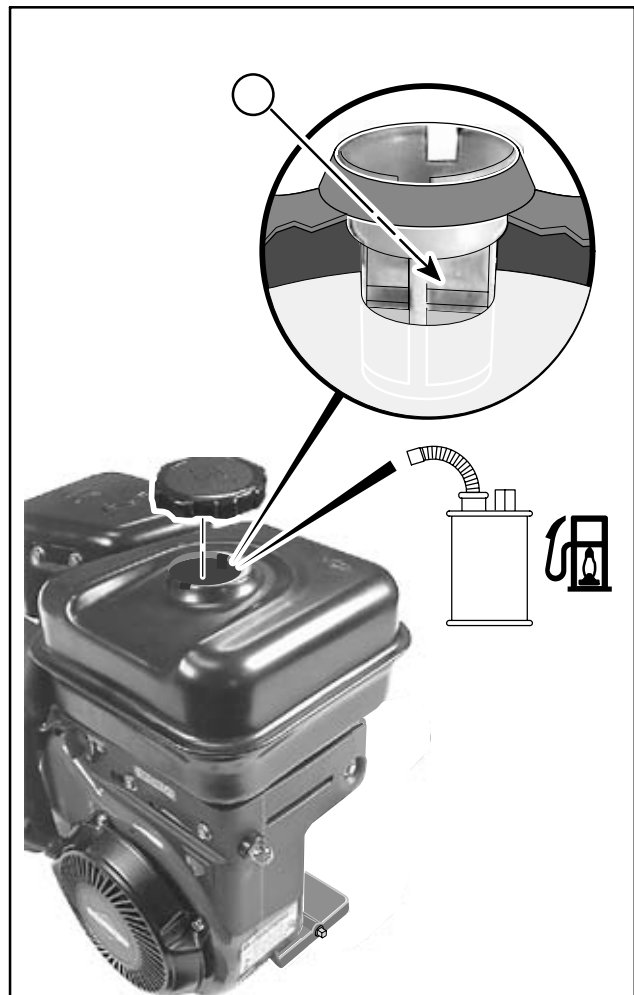

Starting Engine

1. Check oil level.
2. Fill kerosene tank with kerosene.
3. Fill petrol tank with petrol per the equipment manufacturer's instructions.
4. Move CHOKE to choke position (A).
5. Move throttle control to fast position, if equipped.
6. Open kerosene shut off valve (B).
7. Push rocker switch to ON position (C).
8. Push primer bulb three times (D).
9. Grasp rope handle. Pull slowly until resistance is felt, then pull rapidly to start engine and avoid kickback (E).

CAUTION

This engine is shipped from Briggs & Stratton without oil. If you start the engine without oil, the engine will be damaged beyond repair and will not be covered under warranty.



WARNING



Rapid retraction of starter cord (kickback) will pull hand and arm toward engine faster than you can let go.

Broken bones, fractures, bruises or sprains could result.

- When starting engine, pull cord slowly until resistance is felt, then pull rapidly.
- Direct coupled equipment components such as, but not limited to, blades, impellers, pulleys, sprockets, etc., must be securely attached.

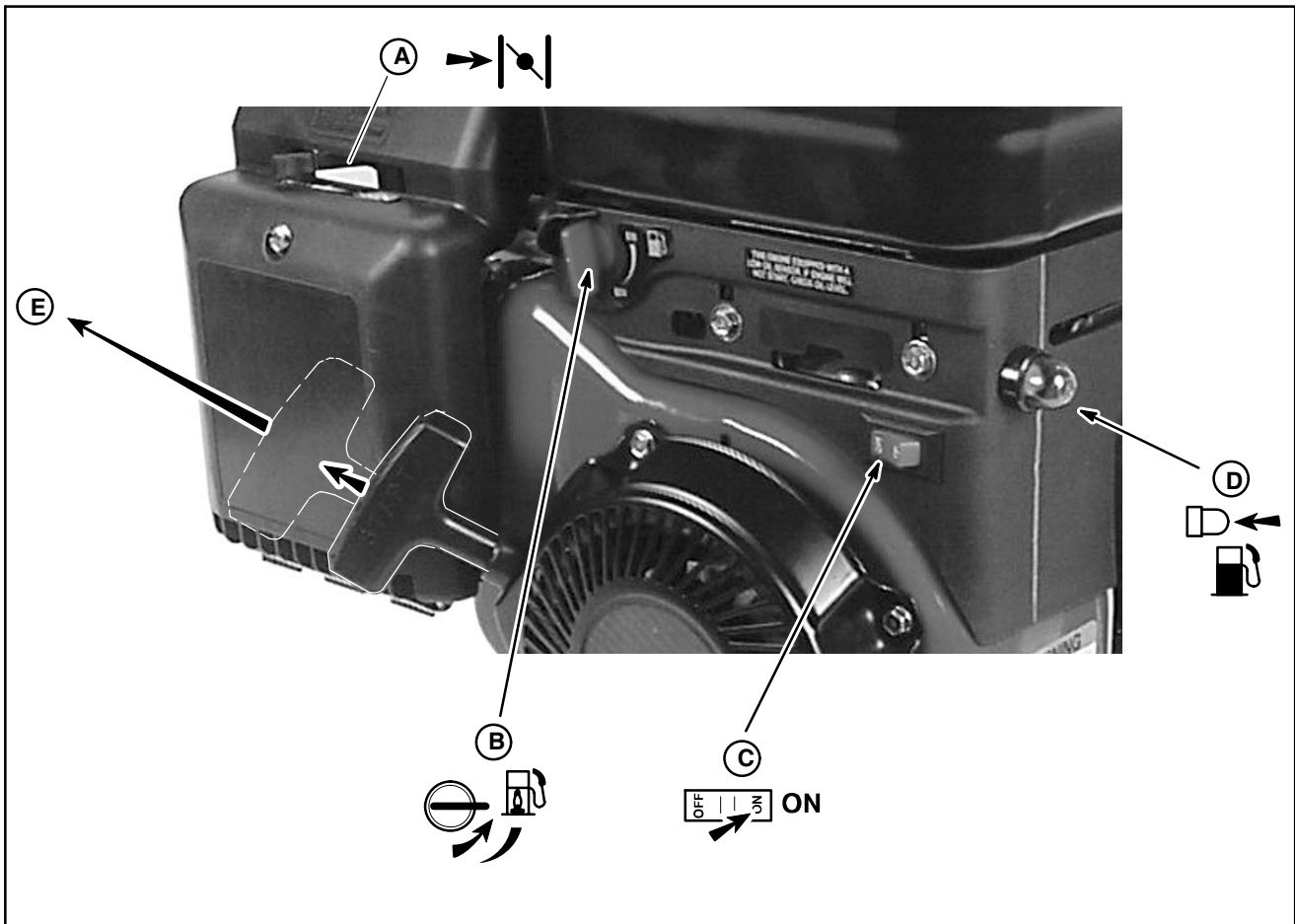

Adjusting Choke

After engine has started, slowly adjust choke to OPEN (A) position as engine warms up.

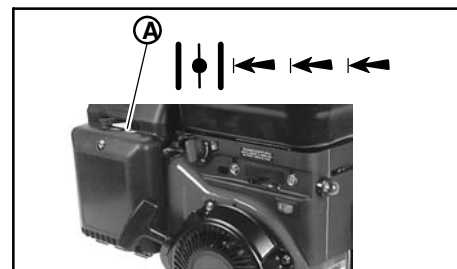

Operation

Do not tip engine or equipment at angle which causes kerosene or petrol to spill.



WARNING

The manufacturer of the equipment on which this engine is installed specifies top speed at which the engine will be operated. **DO NOT EXCEED** this speed.

Stopping Engine



WARNING

Do not stop engine by moving choke control to CHOKE.

Backfire, or explosion can cause severe burns or death. Engine damage may occur.

1. Do not move choke lever. (A)
2. Push stop switch to OFF position (1).
3. Close kerosene shut off valve (2).

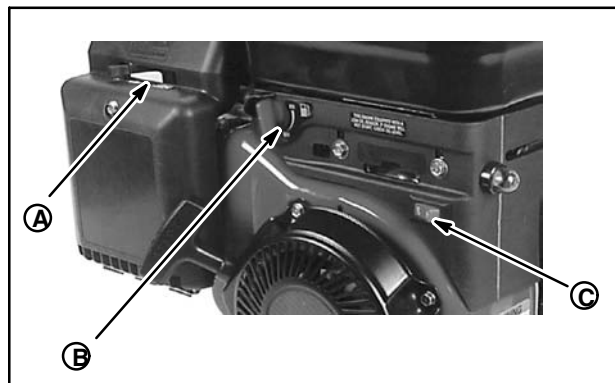

Troubleshooting

Starter Handle will Not Pull

Place equipment on flat level surface.

Remove all external equipment/engine loads before starting engine.

Direct coupled equipment components such as, but not limited to, blades, impellers, pulleys, sprockets, etc., must be securely attached.

Engine will Not Start

Out of Fuel

- Add kerosene to tank.
- Prime engine.

Engine Flooded

- Set choke (if equipped) to OPEN/RUN position, and continue to pull starter handle.

Spark Plug Fouling

- Check and ensure the spark plug is clean. Check the gap with a feeler gage and reset to .76 mm or .030 in. if necessary.
- Replace the spark plug if upon inspection the electrode is burned or worn.

Engine is Smoking or Running Rough

Engine may have been tipped during transport.

- Check for fouled spark plug.
- Check air cleaner filter for oil saturation. If clean but saturated, squeeze in clean, absorbant cloth to remove **ALL EXCESS** oil. If filter is dirty see page 11 for servicing air cleaner.

Need Assistance?

Go to www.briggsandstratton.com



WARNING

- Ensure fuel cap is in place before starting engine
- Turn engine OFF and let engine cool at least 2 minutes before removing fuel cap.
- Do not crank engine with spark plug removed.

CAUTION

If engine is tipped to transport equipment, to remove debris, to drain oil, etc., **keep the spark plug side of engine up.**

Engine Specifications

CAUTION

Operation of this engine is for the application it was intended for. All the components used to build this engine assembly must remain in place for the proper operation of this engine.

We recommend that you use an authorized Briggs & Stratton Service Dealer for all maintenance and service of the engine and engine parts. Use only genuine Briggs & Stratton parts.

Model Series 120000

Bore 2.69 in. (68.26 mm)
 Stroke 2.04 in. (52 mm)
 Displacement 11.57 cu. in. (190 cc)

Tune-up Specifications

Armature air gap 0.010 – 0.014 in. (0.25 – 0.36 mm)
 Spark plug gap 0.030 in. (0.76 mm)
 Valve clearance with valve springs installed and piston 1/4 in. (6 mm) past top dead center (check when engine is cold). See Repair Manual P/N 270962.
 Intake 0.004 – 0.006 in. (0.10 – 0.15 mm)
 Exhaust 0.009 – 0.011 in. (0.23 – 0.28 mm)

Note: For practical operation, the horsepower loading should not exceed 85% of rated horsepower. Engine power will decrease 3-1/2% for each 1,000 feet (300 meters) above sea level and 1% for each 10° F (5.6° C) above 77° F (25° C). It will operate satisfactorily at an angle up to 15°.

Model, Type and Code Number

To get replacement parts or technical assistance in the future write you engine Model, Type and Code number along with the date of purchase here. These numbers are located on your engine. For the location, see page 3, **Engine Features**.

Model Series

--	--	--	--	--	--

Type

--	--	--	--	--	--

Code

--	--	--	--	--	--	--	--

Technical Information

Power Ratings: The power ratings for an individual engine model are initially developed by starting with SAE (Society of Automotive Engineers) code J1940 (Small Engine Power & Torque Rating Procedure) (Revision 2002-05). Given both the wide array of products on which our engines are placed, and the variety of environmental issues applicable to operating the equipment, it may be that the engine you have purchased will not develop the rated horsepower when used in a piece of power equipment (actual “on-site” power). This difference is due to a variety of factors including, but not limited to, the following: differences in altitude, temperature, barometric pressure, humidity, fuel, engine lubrication, maximum governed engine speed, individual engine to engine variability, design of the particular piece of power equipment, the manner in which the engine is operated, engine run-in to reduce friction and clean out of combustion chambers, adjustments to the valves and carburetor, and other factors. The power ratings may also be adjusted based on comparisons to other similar engines utilized in similar applications, and will therefore not necessarily match the values derived using the foregoing codes.

Engine Maintenance

Regular maintenance will improve the performance and extend the life of the engine. See any Authorized Briggs & Stratton Dealer for service. **Use only genuine Briggs & Stratton parts. Other parts may not perform as well, may damage the engine, and may result in injury.** In addition, use of other parts may void your warranty.

WARNING

Unintentional sparking can result in fire or electric shock.

Fire or explosion can cause severe burns or death.

Unintentional start-up can result in entanglement, traumatic amputation, or laceration.

Before performing maintenance or repairs:

- Disconnect spark plug wire and keep it away from spark plug.
- Disconnect battery at negative terminal (only engines with electric start).
- Use only correct tools.

When testing for spark:

- Use approved spark plug tester.
- Do not check for spark with spark plug removed.

Follow the instructions and schedules indicated below.

Task	Every 8 Hours or Daily	25 Hours	50 Hours	100 Hours	100-400 Hours
Check Oil Level					
Clean Debris					
Service Air Cleaner*					
Change Oil **					
Replace Spark Plug					
Clean Air Cooling System					
Clean Combustion Chamber					

* Clean more often under dusty conditions or when airborne debris is present. Replace air cleaner, if very dirty.

** **Change oil after first 5 to 8 hours of use**, then every 50 hours. Change oil every 25 hours when operating the engine under heavy load or in high temperatures.

Changing Oil

Change oil after first 5 to 8 hours of use, then every 50 hours. Change oil every 25 hours when operating the engine under heavy load or in high temperatures.

1. Change oil while the engine is warm.
2. Clean around oil drain plug.
3. Remove plug and drain oil into appropriate receptacle.

CAUTION

Used oil is a hazardous waste product. Dispose of used oil properly. Do not discard with household waste. Check with your local authorities, service center, or dealer for safe disposal/recycling facilities.

4. Clean oil drain plug before reinstalling.
5. Clean around oil filler plug and remove.
6. Place engine level. Add about 5/8 quart (20 ounces: 0.6 liter) new oil. Oil should be full (almost overflowing). Replace plug before starting engine
7. Clean oil filler plug before reinstalling.

WARNING

Disconnect spark plug wire and keep it away from spark plug while performing maintenance.

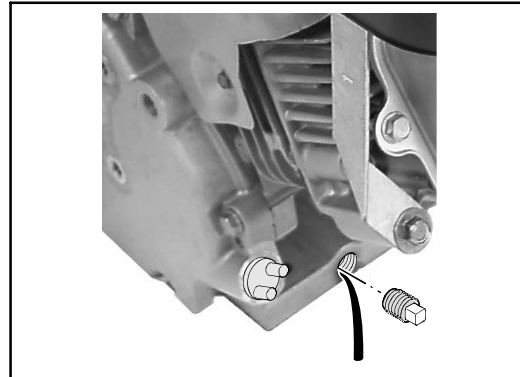

Air Cleaner

1. Loosen cover screw.
2. Remove cover and air cleaner assembly from base.
3. Remove air cleaner assembly from inside of cover and disassemble.

4. To service foam air cleaner:

Wash in liquid detergent and water. Squeeze dry in clean cloth. Saturate in engine oil. Squeeze in clean, absorbent cloth to remove ALL EXCESS oil. If very dirty or damaged, replace it.

CAUTION

Do not use pressurized air or solvents to clean foam. Pressurized air can damage foam; solvents will dissolve foam.

5. Reassemble retainer on foam air cleaner. Install this assembly into cover.
6. Insert tabs on cover into slots in base. Tighten cover screw securely.

WARNING

Ensure air cleaner and cover are properly reinstalled before starting engine.

Fire could occur if engine is started with out cover in place.

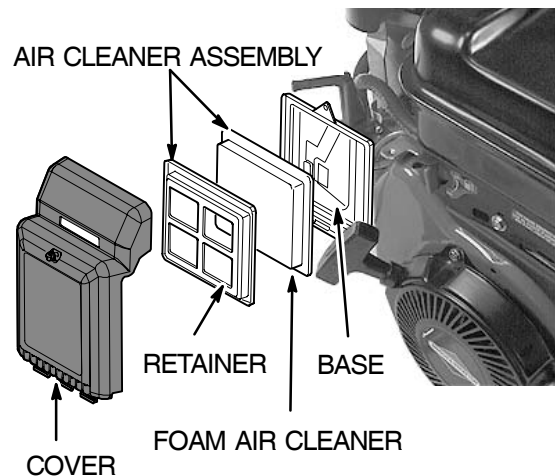

Spark Plug

Check the spark plug every 100 hours. Replace the spark plug if upon inspection the electrode is burned or worn. Ensure the spark plug is clean. Check the gap with a feeler gage and reset to .76 mm or 0.030 in. if necessary. Use only Briggs & Stratton Spark Tester (part number 19368) to check for spark.

Note: In some areas, local law requires using resistor spark plug to suppress ignition signals. If this engine was originally equipped with resistor spark plug, use same type for replacement.

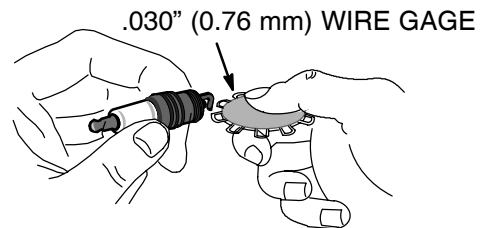

Cleaning Debris

Daily or before every use, clean accumulated debris from engine. Keep linkage, spring and controls clean. Keep area behind and around muffler free of any combustible debris.

CAUTION

Do not use water to clean engine parts. Water could contaminate fuel system. Use a brush or dry cloth.



WARNING

Engine parts should be kept clean to reduce the risk of overheating, and igniting debris buildup.

Fuel System

Replacement parts for fuel system (cap, hoses, tanks, filters, etc.) must be the original parts, otherwise fire can occur.



WARNING

Fire may occur if non-original equipment manufactured parts are used for replacement.

Combustion Deposits

We recommend that after every 100-400 hours you have an authorized Briggs & Stratton Service Dealer remove combustion deposits from the cylinder, cylinder head, top of piston, and around valves.

Air Cooling System

Debris may clog engine's air cooling system, especially after prolonged service.

Remove blower housing and clean area shown to prevent overheating and engine damage.

When reinstalling housing ensure all hoses and wires are in place.



WARNING

Disconnect spark plug wire and keep it away from spark plug while performing maintenance.



REMOVE
BLOWER
HOUSING TO
CLEAN
AIR COOLING
SYSTEM

Storage



WARNING

Kerosene and its vapors are extremely flammable and explosive.

Fire or explosion can cause severe burns or death.

WHEN STORING KEROSENE OR EQUIPMENT WITH FUEL IN TANK

- Store away from furnaces, stoves, water heaters or other appliances that have pilot light or other ignition source because they can ignite fuel vapors.

WHEN TRANSPORTING EQUIPMENT

- Transport with fuel tank EMPTY.

If engine is stored over 30 days, prepare as follows:

1. Operate until fuel tank is empty, if possible
2. While engine is still warm, change oil.
3. Remove spark plug and pour about 1/2 oz. (15 ml.) of engine oil into cylinder. Replace spark plug, but do not attach spark plug wire. Crank engine over by slowly pulling rope handle to distribute oil.
4. Clean engine of accumulated debris.
5. Store in a clean, dry area. Do not store in same area as a stove, furnace, water heater, or other appliance that uses a pilot light or has a device that can create a spark.

Service

See an Authorized Briggs & Stratton Service Dealer. Each one carries a stock of Genuine Briggs & Stratton Parts and is equipped with special service tools. Trained mechanics assure expert repair service on all Briggs & Stratton engines. Only dealers advertising as "Authorized Briggs & Stratton" are required to meet Briggs & Stratton standards.

When you purchase equipment powered by a Briggs & Stratton engine, you are assured of highly skilled, reliable service at more than 30,000 Authorized Service Dealers worldwide, including more than 6,000 Master Service Technicians. Look for these signs wherever Briggs & Stratton service is offered.



You may find the nearest Authorized Service Dealer in our dealer locator map at

www.briggsandstratton.com

Need Assistance?

Go to **www.briggsandstratton.com**

PARTIAL LIST OF GENUINE BRIGGS & STRATTON PARTS

Oil	10030C
Filter – Air Cleaner Foam	696263
Resistor Spark Plug	802592
Standard Spark Plug	492167
Spark Pug Wrench	89838
Spark Tester	19368
Oil Pump Kit	5056

(uses standard electric drill to remove oil from engine quickly)

An illustrated shop manual includes common specifications and detailed information covering adjustment, tune-up and repair of Briggs & Stratton single cylinder, OHV, 4 cycle engines. It is available for purchase from an Authorized Briggs & Stratton Service Dealer.

Warranty

Effective January 1, 2006 replaces all undated Warranties and all Warranties dated before January 1, 2006.

LIMITED WARRANTY

Briggs & Stratton Corporation will repair or replace, free of charge, any part(s) of the engine that is defective in material or workmanship or both. Transportation charges on product submitted for repair or replacement under this warranty must be borne by purchaser. This warranty is effective for the time periods and subject to the conditions stated below. For warranty service, find the nearest Authorized Service Dealer in our dealer locator map at www.briggsandstratton.com.

THERE IS NO OTHER EXPRESS WARRANTY. IMPLIED WARRANTIES, INCLUDING THOSE OF MERCHANTABILITY AND FITNESS FOR A PARTICULAR PURPOSE, ARE LIMITED TO ONE YEAR FROM PURCHASE, OR TO THE EXTENT PERMITTED BY LAW ANY AND ALL IMPLIED WARRANTIES ARE EXCLUDED. LIABILITY FOR INCIDENTAL OR CONSEQUENTIAL DAMAGES ARE EXCLUDED TO THE EXTENT EXCLUSION IS PERMITTED BY LAW. Some states or countries do not allow limitations on how long an implied warranty lasts, and some states or countries do not allow the exclusion or limitation of incidental or consequential damages, so the above limitation and exclusion may not apply to you. This warranty gives you specific legal rights and you may also have other rights which vary from state to state and country to country.

WARRANTY TERMS**

Brand / Product Type	Consumer Use	Commercial Use	Condition of Warranty Term
Classic™	1 year	90 days	2 years Consumer Use in European Union
Etek™	1 year	1 year	
Extended Life Series™	2 years	1 year	
Fource™	2 years	90 days	
I/C®	2 years	1 year	
Industrial Plus™	2 years	1 year	
Intek™ (Kool Bore)	2 years	90 days	
Intek™ (Sleeve Bore)	2 years	1 year	
Kerosene fuel operated engines	1 year	90 days	
Power Built™ OHV	2 years	90 days	
Q45™	2 years	90 days	
Quantum®	2 years	90 days	
Quattro™	2 years	90 days	
Sprint™	2 years	90 days	
Vanguard™	2 years	2 years	
2-Cycle Snow engine	2 years	90 days	
Touch-N-Mow® Starter	5 years	90 days	Equipped on Quantum® or Intek™ engines

Engines used on Home Standby Generator applications are warranted under consumer use only. This warranty does not apply to engines on equipment used for prime power in place of a utility. **Engines used in competitive racing or on commercial or rental tracks are not warrantied.

The warranty period begins on the date of purchase by the first retail consumer or commercial end user, and continues for the period of time stated in the table above. "Consumer use" means personal residential household use by a retail consumer. "Commercial use" means all other uses, including use for commercial, income producing or rental purposes. Once an engine has experienced commercial use, it shall thereafter be considered as a commercial use engine for purposes of this warranty.

No warranty registration is necessary to obtain warranty on Briggs & Stratton products. Save your proof of purchase receipt. If you do not provide proof of the initial purchase date at the time warranty service is requested, the manufacturing date of the product will be used to determine the warranty period.

About Your Engine Warranty

Briggs & Stratton welcomes warranty repair and apologizes to you for being inconvenienced. Any Authorized Service Dealer may perform warranty repairs. Most warranty repairs are handled routinely, but sometimes requests for warranty service may not be appropriate. For example, warranty would not apply if engine damage occurred because of misuse, lack of routine maintenance, shipping, handling, warehousing or improper installation. Similarly, warranty is void if the serial number of the engine has been removed or the engine has been altered or modified.

If a customer differs with the decision of the Service Dealer, an investigation will be made to determine whether the warranty applies. Ask the Service Dealer to submit all supporting facts to his Distributor or the Factory for review. If the Distributor or the Factory decides that the claim is justified, the customer will be fully reimbursed for those items that are defective. To avoid misunderstanding which might occur between the customer and the Dealer, listed below are some of the causes of engine failure that the warranty does not cover.

Normal wear:

Engines, like all mechanical devices, need periodic parts service and replacement to perform well. Warranty will not cover repair when normal use has exhausted the life of a part or an engine.

Improper maintenance:

The life of an engine depends upon the conditions under which it operates, and the care it receives. Some engines are used in dusty or dirty conditions, which can cause premature wear. Wear caused by dirt, dust, or other abrasive material that has entered the engine because of improper maintenance, is not covered by warranty.

This warranty covers engine related defective material and/or workmanship only, and not replacement or refund of the equipment to which the engine may be mounted. Nor does the warranty extend to repairs required because of:

1. PROBLEMS CAUSED BY PARTS THAT ARE NOT ORIGINAL BRIGGS & STRATTON PARTS.
2. Equipment controls or installations that prevent starting, cause unsatisfactory engine performance, or shorten engine life. (Contact equipment manufacturer.)
3. Leaking carburetors, clogged fuel pipes, sticking valves, or other damage, caused by using contaminated or stale fuel.
4. Parts which are scored or broken because an engine was operated with insufficient or contaminated lubricating oil, or an incorrect grade of lubricating oil (Check and refill when necessary, and change at recommended intervals.) OIL GARD® may not shut down running engine. Engine damage may occur if oil level is not properly maintained.
5. Repair or adjustment of associated parts or assemblies such as clutches, transmissions, remote controls, etc., which are not manufactured by Briggs & Stratton.
6. Damage or wear to parts caused by dirt, which entered the engine because of improper air cleaner maintenance, re-assembly, or use of a non-original air cleaner element or cartridge. At recommended intervals, clean and/or replace the filter as stated in the Operator's Manual.
7. Parts damaged by over-speeding, or overheating caused by grass, debris, or dirt, which plugs or clogs the cooling fins, or flywheel area, or damage caused by operating the engine in a confined area without sufficient ventilation. Clean engine debris at recommended intervals as stated in the Operator's Manual.
8. Engine or equipment parts broken by excessive vibration caused by a loose engine mounting, loose cutter blades, unbalanced blades or loose or unbalanced impellers, improper attachment of equipment to engine crankshaft, over-speeding or other abuse in operation.
9. A bent or broken crankshaft, caused by striking a solid object with the cutter blade of a rotary lawn mower, or excessive v-belt tightness.
10. Routine tune-up or adjustment of the engine.
11. Engine or engine component failure, i.e., combustion chamber, valves, valve seats, valve guides, or burned starter motor windings, caused by the use of alternate fuels such as, liquified petroleum, natural gas, altered gasolines, etc.

Warranty service is available only through authorized service dealers by Briggs & Stratton Corporation. Locate your nearest Authorized Service Dealer in our dealer locator map on www.briggsandstratton.com.